



# Storage Refrigerator

# GUR700X



Item number	63318510000GUR700X	Taric goods code	8418501990
EAN code	5704704016330	QTY in 40HQ	45

### Short Description

Specially manufactured in high-quality stainless steel for intensive professional applications, featuring a very robust design and perfect finishing.

Stainless steel doors with ergonomic, full-length, robust, perfectly integrated handle that ensures practical opening of the door that avoids dust and dirt collection.

Hinged doors with automatic return for a perfect closing that minimize temperature gain. Doors have a 120° dwell position and closes automatically at less than 90°.

Intuitive digital control allows temperature parameters to be adjusted easily and quickly.

Door switch stops the fan when door is opened to avoid cold air exiting the interior, thus saving energy.

Stamped guides with rounded edges enable more convenient cleaning operations without any difficulties. Placing and adjusting the grids is also easier than ever. Plastic-coated wire grids allow storage of different packaging types and have a maximum loading capacity of up to 40 kg.

Removable pull-out/ push-in magnetic door gasket to keep maximum hygiene and maintain the insulating properties.

### Key features

- Right hinged self-closing door with 120° dwell position
- Suitable for GN 2/1 containers
- Height-adjustable stainless legs 125-200mm
- 3 Epoxy-coated wire shelves - max 40 kg capacity
- AISI 304 stainless steel internally
- AISI 201 stainless steel externally
- Also available as 60 Hz for marine / offshore as an order item
- 1 set of door-kit for reversing the door can be purchased as an additional accessory

### Measurement Drawings

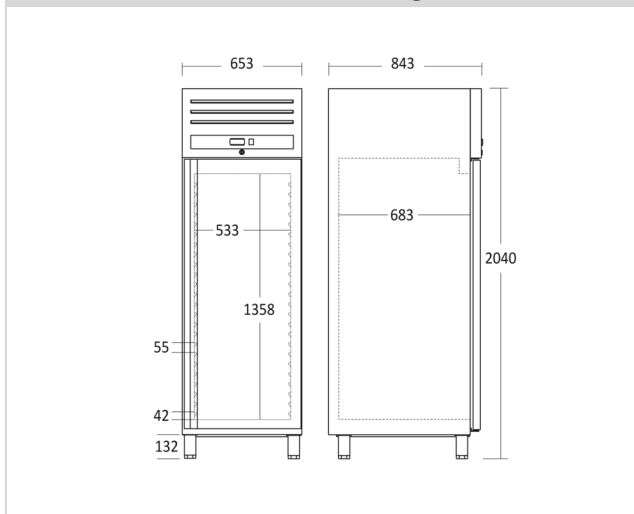

### Dimensions and weight

Product dimensions, HxWxD, mm	2040 x 653 x 842
Product depth w/handle, mm	842
Packaging dimensions, HxWxD, mm	2100 x 740 x 920
Gross- / Net volume, L	543 / 461
Internal dimensions, HxWxD, mm	1358 x 533 x 683
Gross- / Net weight, kg	123 / 112

### Performance and consumption

Energy efficiency class	C
Daily Energy Consumption, kWh/24	1,58
Annual energy cons. kWh/a	577
Energy Efficiency Index (EEI)	43,23
Noise level, dB(A)	55
Refrigeration / freezing technique	Ventilated
Climate class	4
Type of refrigerant / gas gr.	R600a / 98
Temperature range °C	-2 / 8

### Installation and power

Voltage / hertz, V/hz	220-240V / 50hz
No. of electrical phases	1L+N
Watt / Ampere, W/A	183 / 0.9
Length of Powercord, cm	300

### Design and comfort

Digital display	Yes
Internal light	No light
External thermometer	No
Self closing / reversible door	Yes/Yes
Door- / lid type	Right hinged
Handle	Integrated
Number of feet	4
Number of castors, pcs	0
Lock & Key	Yes

### Colour and material

Inside-/outside colour	Stainless Steel/Stainless Steel
Colour and material of door/lid	Stainless steel solid

### Features

Number of shelves	3
Adjustable shelves	Yes
Max loading per shelf/basket, kg	40
Large shelves size WxD, mm	530x650
Small shelves size WxD, mm	530x650

# scandomestic